

Custom Microphone Panel High Current Expansion Board

Product Description

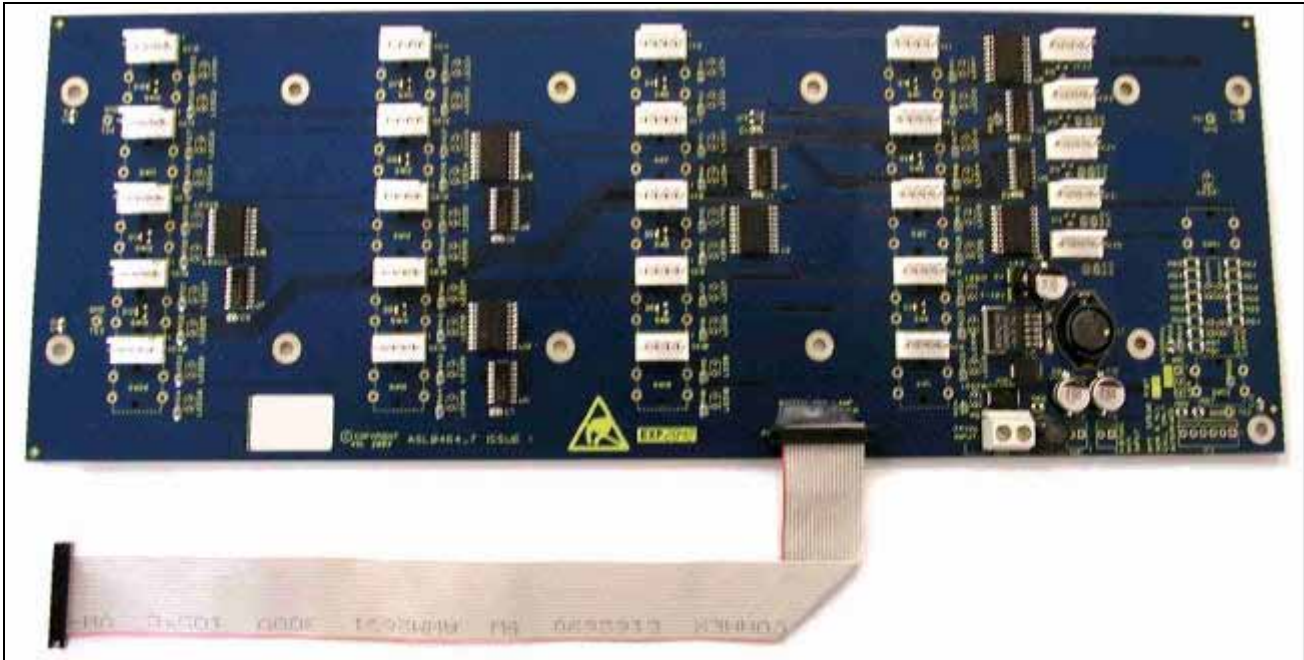

MEB20HC

The MEB20HC is supplied as an open Printed Circuit Board for inclusion into custom “paging” and “fire” microphone console designs with higher current drive requirements, e.g. filament lamps and high power LEDs. It is designed to work with the CMB10 Custom Microphone Board and the ASL range VAR Router/System Controllers.

The MEB20HC provides connections for twenty configurable selection switches, each having a high current ‘busy’ LED and ‘Select’ LED. Connection for dual ‘Speak-Now’ and “Wait” LEDs is also provided along with four configurable key-switch inputs and associated control outputs.

All panel connections are presented on simple crimp style plug and socket connectors with field connections via screw terminal blocks for ease of cabling. Connections to the CMB10 are via a single pluggable ribbon cable.

For further details please refer to the DSP Router/System Controller Handbook and the CMB10 installation guide.

CE Information.

This product is classified as a component and, as such, cannot be individually CE marked. Its EMC performance depends on its installation. In particular, how it is cabled and enclosed.

The responsibility for EMC compliance therefore falls on the system integrator responsible for incorporating these products into the particular custom microphone console of their design.

ASL offers the following guidelines:

- Use an overall metal enclosure with good bonding between panels.
- Mount the PCB(s) to the enclosure using suitable metal pillars.
- Use foil screened cable for interconnection with other equipment.
- Terminate the cable screens as directly as possible to the metal enclosure on entry. Preferably clamped within the shell of a connector.

Safety and Precautions

ELECTRICAL SAFETY

Always replace blown fuses with the correct type and rating. Ensure power supply cabling is adequately rated.

ENVIRONMENTAL PRECAUTIONS

The temperature and humidity ranges shown in the specifications for this product must not be exceeded. This equipment must not be installed in an area that is subject to a corrosive atmosphere, excessive moisture or may allow water or other liquids to come into contact with the unit or its external connections.

ESD PRECAUTIONS

This product contains static-sensitive devices. Observe ESD precautions when working on the equipment with the cover removed.

HOT PLUGGING

Only make/break connections to these products with all power removed. Failure to do so may damage the product.

To install this product you will need;

- This MEB20HC and a CMB10 unit.
- A metal enclosure with suitable fixing points (see drilling plan).
- Suitable Switches and indicators.
- A pair of wire cutters/strippers and a suitable crimp tool for switch/LED and microphone cabling e.g. MOLEX part no. 69008-0956 or Farnell part nos: 285-511 or 143-520

Connection Details

Fig.1 – MEB20HC Connections and Link Settings

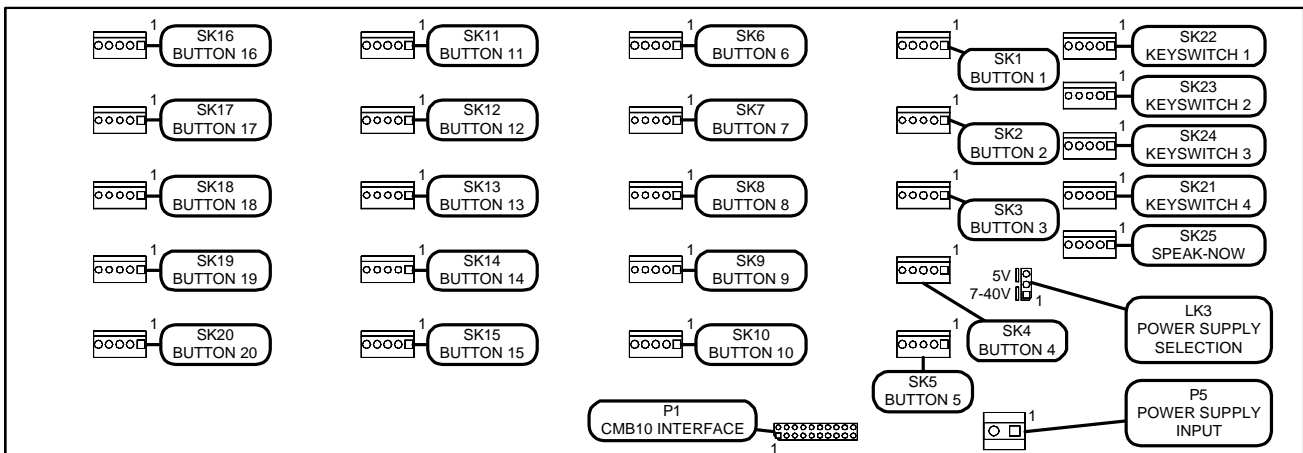

Fig.1. Connection details

System and Power Connections

P1 - CMB10 Interface

Connect to the CMB10 Expansion Interface P8 via ribbon cable provided. Ensure that LK3 jumper on the CMB10 is fitted to pins 2 and 3 for correct operation. Refer to the CMB10 Installation Guide for further information.

P5 – Power Supply Input

Pin	Function	Notes
1	+7 to +40V Input	Power supply input for all indicators.
2	0V Input	See Power Supply Selection below.

Connection details (continued)

SK1 to SK20 –Buttons 1-20 and Busy/Select Indicators			
Pin	Function	Destination	Notes
1	Busy Indicator *	Cathode of external indicator	Operation dependent upon button function. See below for electrical specifications.
2	Select Indicator *	Cathode of external indicator	
3	Select Switch *	External switch	Momentary normally open pushbutton switch.
4	Select Switch *	External switch	
5	+5V to +40Vdc	Anodes of external indicators	Suitable series resistors required for LEDs. See Power Supply Selection for voltage setting.

SK21 – Keyswitch 4 and Indicators			
Pin	Function	Destination	Notes
1	Indicator 1 *	Cathode of external indicator	Operation dependent upon keyswitch function. See below for electrical specifications.
2	Indicator 2 *	Cathode of external indicator	
3	Keyswitch *	External keyswitch	Momentary normally open pushbutton switch or latching keyswitch.
4	Keyswitch *	External keyswitch	
5	+5V to +40Vdc	Anodes of external indicators	Suitable series resistors required for LEDs. See Power Supply Selection for voltage setting.

SK22 – Keyswitch 1 and Indicators			
Pin	Function	Destination	Notes
1	No connection		
2	No connection		
3	Keyswitch *	External keyswitch	Momentary normally open pushbutton switch or latching keyswitch.
4	Keyswitch *	External keyswitch	
5	+5V to +40Vdc		

SK23 – Keyswitch 2 and Wait Indicators			
Pin	Function	Destination	Notes
1	Wait Indicator 1	Cathode of external indicator	Illuminates during chime if selected. See below for electrical specifications.
2	Wait Indicator 2	Cathode of external indicator	
3	Keyswitch *	External keyswitch	Momentary normally open pushbutton switch or latching keyswitch.
4	Keyswitch *	External keyswitch	
5	+5V to +40Vdc	Anodes of external indicators	Suitable series resistors required for LEDs. See Power Supply Selection for voltage setting.

SK24 – Keyswitch 3 and Indicators			
Pin	Function	Destination	Notes
1	Indicator 1 *	Cathode of external indicator	Operation dependent upon keyswitch function. See below for electrical specifications.
2	Indicator 2 *	Cathode of external indicator	
3	Keyswitch *	External keyswitch	Momentary normally open pushbutton switch or latching keyswitch.
4	Keyswitch *	External keyswitch	
5	+5V to +40Vdc	Anodes of external indicators	Suitable series resistors required for LEDs. See Power Supply Selection for voltage setting.

LK3 – Power Supply Selection	
Position	Notes
1-2 (7-40V)	See Power Supply Selection below.
2-3 (5V)	

Connection details (continued)

SK25 – Speak-Now Indicators			
Pin	Function	Destination	Notes
1	Speak-Now Indicator 1	Cathode of external indicator	Illuminates after chime if selected. See below for electrical specifications.
2	Speak-Now Indicator 2	Cathode of external indicator	
3	No connection		
4	No connection		
5	+5V to +40Vdc	Anodes of external indicators	Suitable series resistors required for LEDs. See Power Supply Selection for voltage setting

Notes:

Switches, keyswitches and indicators marked * in the tables above are configurable via the VAR series of Audio Routers. Brief details of configuration options are shown below. Further features are added on a continual basis. Refer to the VAR product manuals for further information.

Configuration options

Button Option	Button function	Busy Indicator Function	Select Indicator Function
Mic Routing	Alternate presses of the button will select and deselect the configured zone(s) ready for paging.	Lights if any zones configured to the button are in use by another source set up to indicate "busy". Paging may still be possible if priority allows.	Flashes after button pressed to confirm selection (if priority allows). Goes steady when PTT pressed to confirm paging.
DVA Routing	Pressing the button starts or stops DVA broadcast to the configured zone(s). Various options are available, e.g. "play once" and "latching".	Lights if any zones configured to the button are in use by another source set up to indicate "busy". DVA operation may still be possible if priority allows.	Lights to indicate DVA broadcast running. Flashes to indicate DVA broadcast ending.
All Call	Alternate presses of the button will select and deselect ALL configured zones from all buttons ready for paging.	Lights if any zones configured to the button are in use by another source set up to indicate "busy".	Flashes after button pressed to confirm selection (if priority allows). Goes steady when PTT pressed to confirm paging.

Keyswitch Option	Keyswitch function	Indicator 1 Function	Indicator 2 Function
Security	When open, prevents operation of buttons configured to it. Usually a latching key operated switch.	No function.	No function.
Listen	Alternate presses allow system audio activity to be fed to a local loudspeaker for monitoring. Usually a momentary pushbutton.	No function.	Lights when Listen function active.

Power Supply Selection

Power supply for all indicators may be selected via three methods dependent upon efficiency requirements and indicator voltage and current limitations:

Method 1 – Using the internal 5Vdc power supply

This method is the most efficient as it utilizes the onboard switch-mode regulator.

All indicators must be rated for 5Vdc operation (LEDs must have suitable current limiting series resistors fitted). The maximum allowable current for each indicator is 100mA. The maximum allowable overall current is 1A.

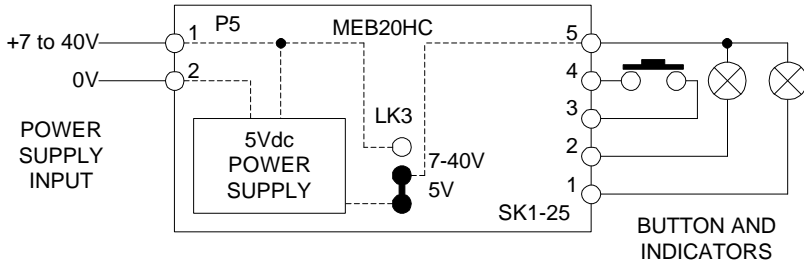

Fig.2. - 5Vdc operation

Method 2 – Using an external 7-40Vdc power supply with a maximum 1 Amp current draw.

This method is less efficient but allows a wider range of indicators to be used up to a maximum overall current limit.

All indicators must be rated to match the power supply voltage used (LEDs must have suitable current limiting series resistors fitted).

The maximum allowable current for each indicator is 100mA. The maximum allowable overall current is 1A.

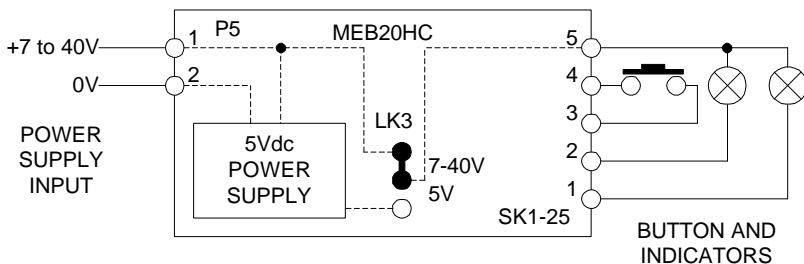

Fig.3. - 7-40Vdc operation <1A

Method 3 – Using an external 7-40Vdc power supply with a current draw of greater than 1 Amp

This method allows the full 100mA capability of all outputs to be utilized simultaneously.

All indicators must be rated to match the power supply voltage used (LEDs must have suitable current limiting series resistors fitted).

The maximum allowable current for each indicator is 100mA. The maximum allowable overall current is 4.8A. Ensure that all cabling and connections are adequately rated.

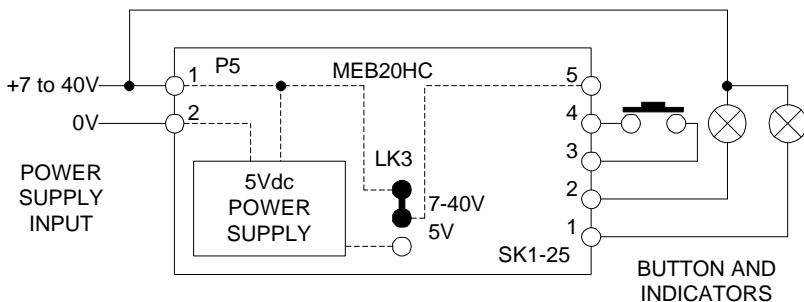

Fig.4. - 7-40Vdc operation >1A

Make no connections to pin 5 of SK1-25.

MECHANICAL DETAIL FOR:
MEB20HC – HIGH CURRENT MICROPHONE EXPANSION BOARD

MINIMUM CLEARANCE BELOW PCB = 4mm
MINIMUM CLEARANCE ABOVE PCB = 20mm

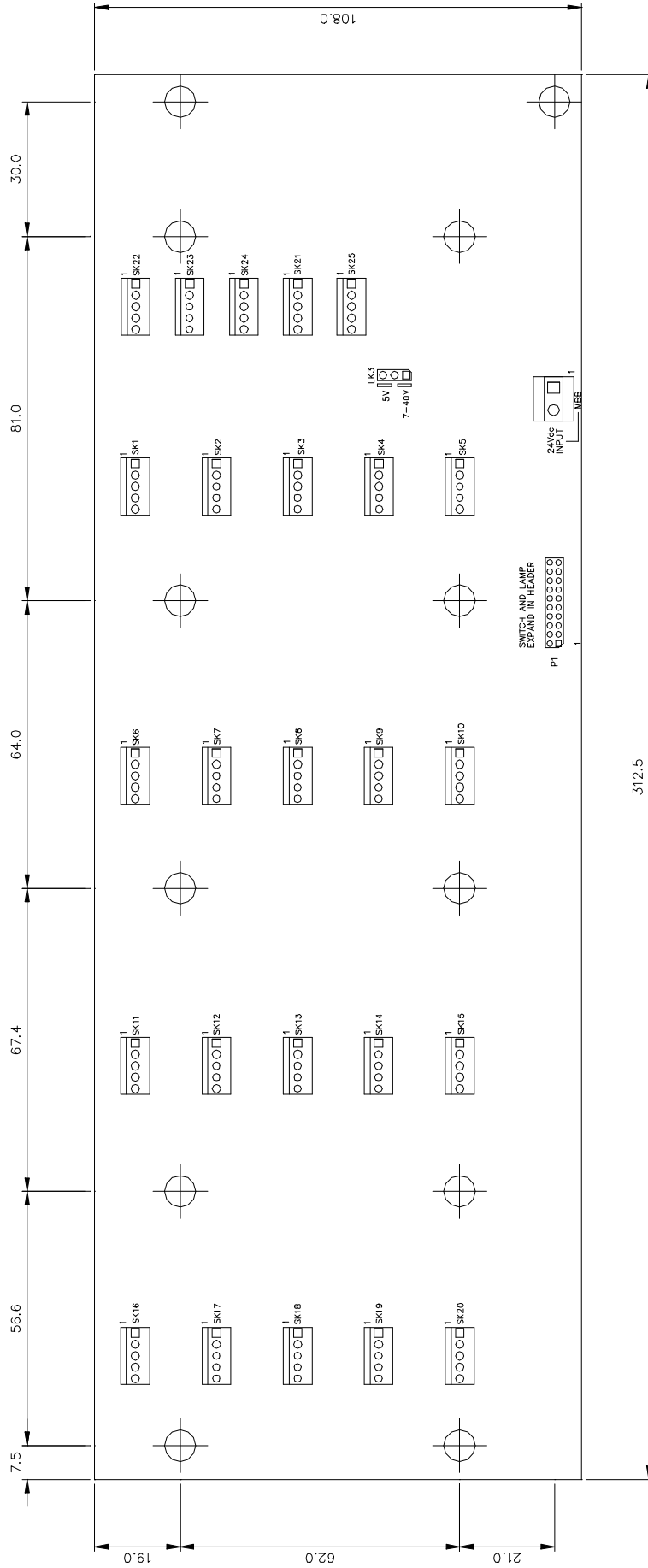

Fig.5. - Mechanical Details

Specifications

Current consumption (max, all LEDs on)	4.8A @ 7-40V DC supply
Output current drive	100mA maximum
Output voltage source	40Vdc maximum
Dimensions (H x W x D)	See Fig. 5
Weight	Approx 200g
Temperature Range (storage and operating)	-5°C to +50°C
Humidity Range	0% to 93% Non Condensing

Manufacturer

Application Solutions Limited, The Riverside Centre, Railway Lane, Lewes, East Sussex, BN7 2AQ, UK
Tel: +44(0)1273 476608, Fax: +44(0)1273 478888,
E-mail: sales@asl-electronics.co.uk, Web: www.asl-audio.co.uk



This equipment is designed and manufactured in the UK by Application Solutions Ltd to a quality system certified to the internationally recognised quality standard: BS EN ISO 9001: 1994

Certificate number: 96-LON-AQ-041

In the interest of continual product development, Application Solutions Ltd reserves the right to make changes to product specification without notice or liability. Information contained in this document is believed to be accurate, however no representation or warranty is given and Application Solutions Ltd. assumes no liability with respect to the accuracy of such information.