

HORN SPEAKER

- 15W 100V LOUDSPEAKER
- HIGH SOUND PRESSURE LEVEL
- U-BRACKET MOUNTING
- ROBUST ABS PLASTIC HOUSING
- WEATHERPROOF TO IP66



OVERVIEW

The SPHO-15W is a 15W 100V horn loudspeaker which gives a high sound pressure level for internal and external applications. The speaker is fitted with a 100V transformer which has four power adjustment tapings of 15W, 7.5W, 3.75W, and 1.9W, plus a low-impedance setting (20ohm). The power adjustment is easily accessed at the rear of the speaker.

The SPHO-15W's ABS body provides good long-term stability, and is sealed to the IP66 environmental standard. Thus the speaker is sealed against the ingress of dust, and is sealed against high pressure water jets. In addition, the body meets the UL94 V-0 flammability standard. The speaker is coloured to match RAL7035 'Light Grey'.

Mounting of the speaker is provided using a stainless-steel 'U' bracket, which provides a number of flexible mounting options. The 100V loudspeaker line connection is provided via a one metre two core cable, which is designed to be terminated to the 100V loudspeaker line site cabling in a suitable local connection box. There is also a strap-on mast bracket available as an accessory. The mast bracket is suitable for use with masts of up to 200mm diameter.

This loudspeaker is optionally available with a DC blocking capacitor fitted, in order to provide compatibility with DC loudspeaker line monitoring systems. The part number for this DC monitoring compatible version is SPHO-15W-DC.

EASE data is available for this speaker on request.

TECHNICAL DATA

Power Tappings 15W / 7.5W / 3.75W / 1.9 (20)W

Frequency Range 677 — 5,400 Hz

Frequency Response 270 — 12,000 Hz

SPL 1W / 1m, peak 108.5 dB

SPL Pmax / 1m, peak 120.3 dB

Sensitivity 1W / 1m 107.2 dB

Dispersion (-10dB) 240° (horizontal) / 240° (vertical)

Temperature range -20 / +90 °C

Dimensions 208 x 5 x 271.5 mm

Weight (net) 2.00 kg

Colour RAL7035 'Light Grey'

Connector 2-pin cable + switch

Mounting 'U' Universal mounting bracket

IP Rating IP66

Accessories SPAC-MB-80 Mast Bracket

Packing Unit 8

POLAR DIAGRAM

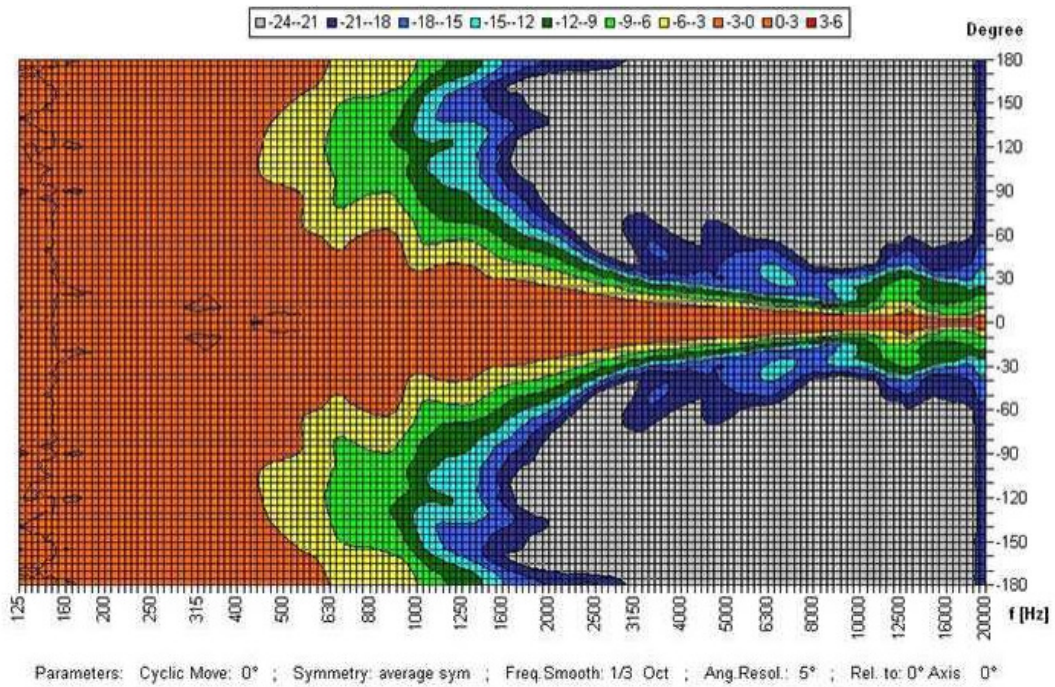

FREQUENCY RESPONSE DIAGRAM

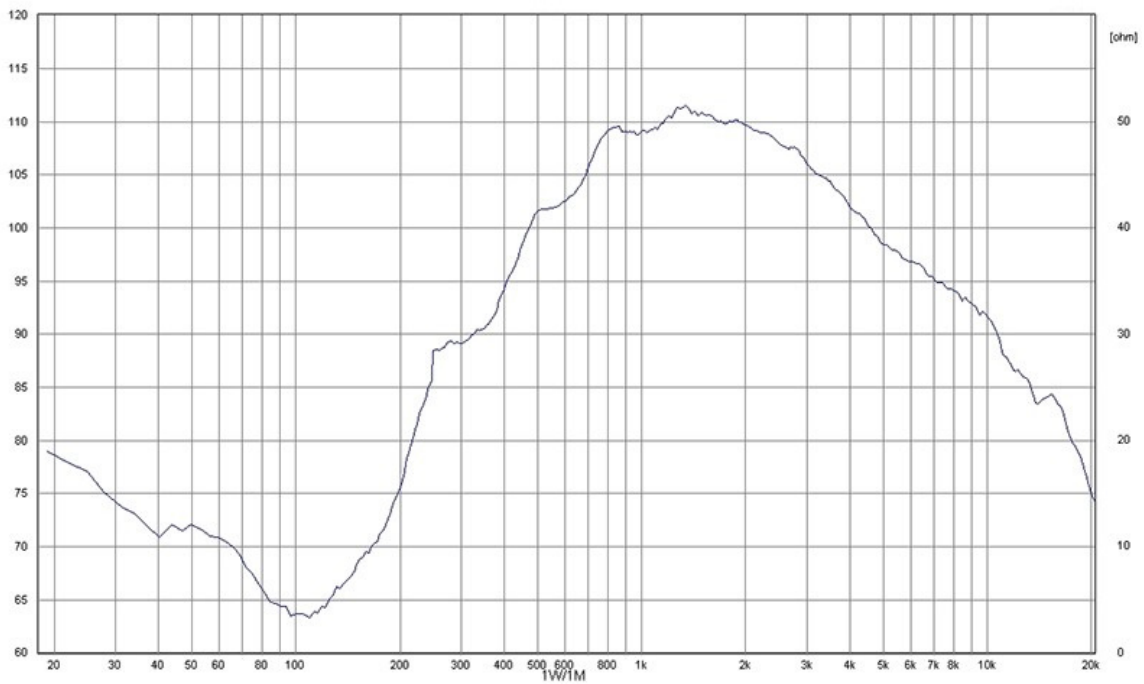

DIMENSIONAL DIAGRAM

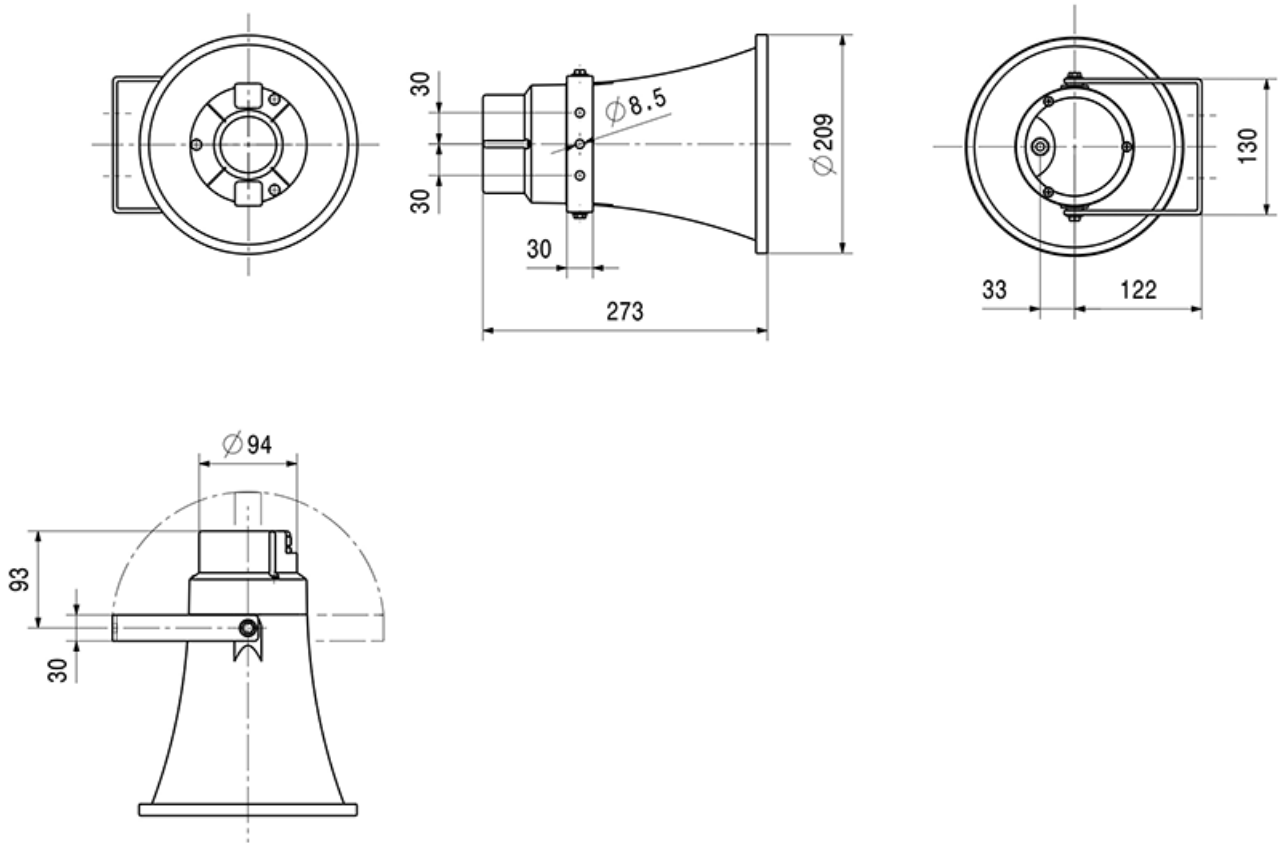

Measurements according to DIN EC 268-5

RoHS complaint (2011/65/EU)



This equipment is designed and manufactured to conform to the following EC standards:
 EMC: EN55103-1/E1, EN55103-2/E5, EN50121-4, ENV50204
 Safety: EN60065

Manufacturer

Application Solutions (Safety and Security) Limited
 Unit 17 - Cliffe Industrial Estate - Lewes - East Sussex - BN8 6JL - U.K.
 Tel: +44(0)1273 405411

www.asl-control.co.uk

All rights reserved.

Information contained in this document is believed to be accurate, however no representation or warranty is given and Application Solutions (Safety and Security) Limited assumes no liability with respect to the accuracy of such information.

